

TRSP Submersible tube system

The TRSP Submersible tube systems with plastic head can be used as a component in numerous air and water treatment or salt water systems. Due to its chemical resistance, the head material POM is suitable for salt water applications, where metal steel systems can not be used. The available systems have a tube diameter of 23, 32 or 36mm. To prevent additional mounting elements such as screws, the construction of the head was designed to be mounted by hand. A sufficient wall thickness of approx. 5mm with a standardized thread is necessary for the installation. For assemblies in thinner walls, we recommend to waive the thread, but to use a counter nut which is available as an option (see drawing). The sealing can be realized with a flat gasket or O-rings (not in scope of delivery). Long submersible tube systems have to be supported at their end to minimize vibrations. An installation of the lamp inside the TRSP happens before the system is screwed into the air or water system and is also doable by hand without tools. Watertightness is given by hand-tight fixation. The cable entry connector is specified for protection class IP68. Alternatively, the systems can be equipped with a splash-proof plug-in connector.

Main applications

Disinfection of UV-transparent media:

- Water disinfection in air washers
- Water disinfection for mobile homes
- Water treatment and algae prevention in cisterns, wells and ponds
- Water treatment in fish farms
- Container disinfection for industrial use

Drawing / Picture

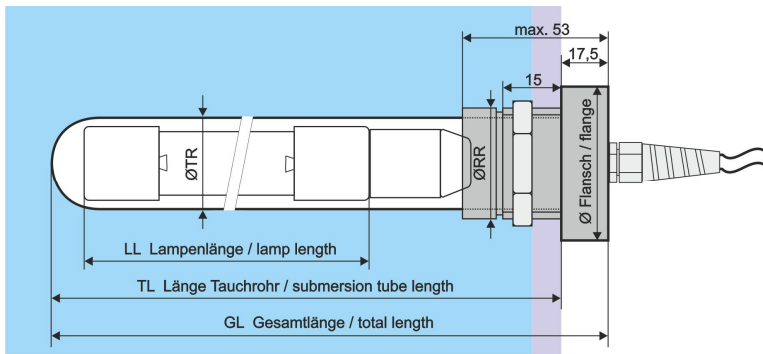

Technical data

Total length GL	TL + 17.5 mm
Lamp length LL	TL - 50 mm
Ambient temperature	0 to 30°C
Cooling	Convection, air flow, water
Installation	Installation position arbitrary, long tubes to be supported by counter bearing
Cable	Optional, rubber cable 4x 0.75 mm ² , 19 AWG, suitable for humid environments
Cable length	5 m (possible max. length depends on used ballast)
Protection class	IP 68 at cable entry, watertight up to 10 bar from head
Safety advice	 Please consider installation advices of TRSP and ballast! Do not bend or damage cable during installation!
Lamp emits dangerous radiation! Protect eyes/skin! Install safety switch-off! Install warning notices! Installation by skilled personal only! Separation from supply while installation and maintenance! No warranty for damages caused by incompatible lamps or wrong adjustments!	

Length according to customers needs, based on necessary submersion depth.

Factory-provided installation of lamp up to total lengths of 1m on request possible (longer systems are packed separately due to risk of breaking).

Standard quartz tube material is PN (RQ200) and PN235 for the lamp (not ozone generating).

By using a conventional ballast, the starter can be integrated into the system.

System	ØTR Submersion tube	ØRR Knurled ring	Thread	Ø Flange
TRSP 23	23 mm	35 mm	M40 x 1.5	52 mm
TRSP 32	32 mm	49 mm	M50 x 2	60 mm
TRSP 36	36 mm	52 mm	M55 x 2.5	68 mm