

# Operating Manual

## Electronic Power Supply

with wide range power supply 85 – 264 VAC



**EVG UVT 16-25W 400mA**  
**EVG UVT 20WHO 670mA**  
**EVG UVT 30WHO 700mA**  
**EVG UVT 40W 425mA**  
**EVG UVT 2x 40W 425mA**  
**EVG UVT 40WHO 800mA**  
**EVG UVT 55WHO 540mA**  
**EVG UVT 75W 425mA**  
**EVG UVT 75WHO 800mA**  
**EVG UVT 80WHO 800mA**

## Imprint

All rights reserved

©Copyright by uv-technik international

Printed in Germany, 15 August 2017

No parts of this operating manual may be reproduced in any form without the prior written permission of UV-Technik international. If any part of this user's manual is reproduced, stored in a retrieval system or transmitted in any form or by any means without obtaining the prior written permission of UV-Technik international, this will be considered as an infringement of the copyright and legal action will be taken. We reserve the right to effect technical changes for the improvement of the equipment described herein or to raise the safety standard of the said equipment without prior notice.

Responsible for the content: UV-Technik international

Layout: UV-Technik international

## Table of contents

<b>Warning notes and symbols in the operating instructions.....</b>	<b>4</b>
<b>1 Device and function description.....</b>	<b>5</b>
<b>2 Safety instructions.....</b>	<b>6</b>
General information .....	6
Appropriate use .....	6
Staff obligation .....	6
Hazards from handling the equipment .....	6
Warranty and liability .....	7
Organizational measures.....	7
Informal safety measures.....	7
Danger due to electricity .....	7
Service, maintenance, remedying faults .....	7
<b>3 Transport, storage, delivery.....</b>	<b>8</b>
<b>4 Order data for equipment .....</b>	<b>8</b>
<b>5 Faults .....</b>	<b>8</b>
Generally .....	8
Failure table .....	9
<b>6 Technical data .....</b>	<b>9</b>
General information .....	9
Equipment range .....	9
Installation .....	10
LED status indicator for types with blink code .....	10
Dimensional drawings .....	11
Connection plan.....	11
<b>7 Hints for installation.....</b>	<b>12</b>
Point of installation .....	12
Connection / cabling.....	12
Cabling of lamps .....	12
Mains supply cabling .....	12
Grounding.....	13
Additional notes for cabling .....	13
Temperature behaviour.....	13
Switching .....	13
Monitoring.....	14
Dimming .....	14
Electromagnetic compatibility.....	14

## Warning notes and symbols in the operating instructions

These operating instructions describe the singled flamed electronic power supply of the wide range EVG UVT series, its operation and its uses. The safety and warning notices explain the safe, proper handling of the device.

You will find the symbols listed below next to all safety and warning instructions in these operating instructions where there is danger to life and limb. An additional signal word indicates the severity of a possible danger.

Observe these notes closely and be especially careful in these cases in order to preclude accidents.

**DANGER!** The signal word marks a danger with high risk or an immediately threatening danger. If it is not avoided, death or very severe injuries / damage to health will result. Damage to property is possible.

**WARNING!** The signal word marks a danger with medium risk or dangerous situation. If it is not avoided, death or very severe injuries / damage to health could result. Damage to property is possible.

**CAUTION!** The signal word marks a danger with low risk or marks a possible danger. If it is not avoided, slight injury / damage to health could be possible. Damage to property is possible.

### The symbols used in these operating instructions have the following meaning:



This symbol warns of a hazard area.



This symbol warns of a hot surface.



This symbol warns of hazardous electrical voltage.

The two following symbols are used to address practices for optimal operation and/or prevention of damage to the equipment. These information are not related to hazardous situations. Additionally, the signal words **ATTENTION** and **NOTE!** are used.



#### **ATTENTION!**

This symbol with signal word is found at those places in the operating instructions which must be observed so that damage or destruction of the equipment is prevented.



#### **NOTE!**

This symbol is found next to notes, tips on operation and useful information.

## 1 Device and function description

The EVG UVT with wide range power supply is an electronic ballast for UV low-pressure lamps and is suitable for all 50/60 Hz mains voltages worldwide. The single or two-lamp units are available in the same size for lamp outputs of 16 ... 75 W. For design and cost reasons, two-lamp devices also have only one lamp circuit, which is why if one lamp fails, the other lamp is extinguished. The ballasts of the series can achieve lamp currents of 0.4 ... 0.8 A. All commercially available lamps are covered by the following standard types.

The EVG UVT is intended for small systems with usually one or two lamps, but is often used for systems with more lamps because of its low price. All devices of the series have a potential-free contact for fault indication and an LED as operating indicator. Individual devices also have a 5 V DC output, which can be used for both, as an operating message and for the connection of an external LED.

The EVG UVT may be installed/operated in any position. The heat dissipation via the housing must however be guaranteed. The maximum housing temperature of 70 ° C at the tc point on the housing cover must not be exceeded. If the appliance is operated permanently at an excessively high temperature, it is likely that the reachable lifetime will be reduced or even damages are possible. There is no independent shutdown at excessive temperature.

EVG UVT devices start UV lamps gently with preheating. The preheat current of the lamp filaments must be observed. Before preheating/igniting the lamp, the device checks whether a lamp is connected (lamp presence test). If no lamp is detected at the output, there is no ignition. By means of this function, ignition voltage peaks are avoided, which could permanently damage the ballast or create a hazard. By warm start, the devices are also suitable for applications with sequential operation and with frequent switching.

The EVG UVT is designed for installation in control cabinets and switch boxes. The device is connected via spring-loaded terminals.

In summary, the EVG UVT has the following major advantages:

- compact design, low weight, low price
- one or two lamps can be connected
- power consistency across the entire input voltage range
- wide-range mains voltage input allows connection to all 50/60 Hz networks worldwide
- error message via potential-free contact and partly via flashing code of the operating LED
- energy efficient operation, low power dissipation
- any operating position/mounting position
- inrush peak current limiter installed
- customer specified devices for special lamps in the above specified power range already possible from 100 pieces

## 2 Safety instructions

### General information

A sound knowledge of all basic safety regulations is essential to ensure safe and fault-free operation of the EVG UVT.

This operating manual contains all important safety regulations to ensure safe operation of the equipment.

This operating manual, and in particular the safety instructions, must be observed by all persons working with the equipment. In addition, all relevant rules and accident prevention regulations relating to the operation site must be observed.

In regular intervals, the operator will check that all personnel are observing the safety regulations.

### Appropriate use

EVG UVT is a microprocessor-based electronic power supply for UV low pressure lamps. Any other use or use above and beyond these terms is defined as inappropriate and is thus dangerous.

The operator may only operate the equipment as stipulated by the operating instructions in this manual.

The following are further conditions for appropriate use:

- the observance of all points listed in this user manual
- compliance with the general and specific safety instructions in this user manual
- compliance with the relevant accident prevention regulations

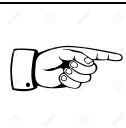

#### ATTENTION!

UV-Technik Speziallampen GmbH is not liable for damage resulting from inappropriate use of the equipment.

### Staff obligation

Before commencing work, all persons entrusted with work to be performed on the EVG UVT undertake the following:

- to observe the safety at work and accident prevention regulations
- to read the chapter on safety and the warnings printed in this manual and to observe them at all times while using the equipment

### Hazards from handling the equipment

The EVG UVT has been manufactured in accordance with the very latest state-of-the-art technology and the recognized rules of safety technology.

#### The equipment may only be used under the following conditions:

- it is used for the purpose for which it was constructed
- in a condition in which the equipment complies with all safety technology requirements



#### DANGER! – HAZARDOUS ELECTRICAL VOLTAGE!

Switch off the main switch and the main contactor before working on the connections of the power on the power supply or the UV lamp, e.g. for a lamp replacement, in order to eliminate the danger of an electric shock.

Reason: During operation, the UV lamp is switched off by semiconductor components. This does not correspond to a safe separation from the mains supply according to VDE! Residual voltages!

#### Attention: Danger of life!

## Warranty and liability

The General sales and delivery conditions of UV-Technik international apply. The operator will have received these terms, at the latest upon signing the contract. They can be found on our website at [www.uv-technik.com](http://www.uv-technik.com) UV-Technik international is not liable for any damage to persons or property arising from any one or more of the following:

- inappropriate use of the EVG UVT
- incorrect assembly, commissioning and operation of the EVG UVT
- operation of the EVG UVT with faulty and/or non functioning safety and protection device
- non observance of the instructions given in the user's manual with reference to the safety, transport, storage, assembly, commissioning, operation and servicing of the device
- unauthorized alterations to the construction of the EVG UVT
- unauthorized repair
- catastrophes, the action of foreign bodies or acts of God
- damages or losses originated from the use or a defect of the EVG UVT

## Organizational measures

All safety devices on the equipment must be tested for correct functioning regularly, prior to carrying out work and at each shift change. Look for external signs of damage.

## Informal safety measures

In addition to this user manual, the generally and locally applicable accident prevention and environmental protection regulations must be made available and observed.

## Danger due to electricity



**DANGER! – HAZARDOUS ELECTRICAL VOLTAGE!**

**Attention: Danger of life!**

A hazard is caused by direct or indirect contact with electricity!

The electrical components of the EVG UVT must be inspected regularly.

### Before commencing work:

- check all equipment components for external signs of damage
- check that all electric cables are in perfect condition

Loose connections must be tightened and damaged wiring replaced immediately.

### Service, maintenance, remedying faults

In the unlikely event of faults occurring on the EVG UVT, the chapter 'Faults' offers information on the causes of the fault and possible remedial action.

If a fault occurs in the device which can not be remedied by means of the fault lists, contact the customer service of UV-Technik international.

Should the EVG UVT suffer damage or defects of any kind, device must be returned to UV-Technik international for inspection or repair.

---

**WARNING!**

Without the permission of UV-Technik international, no alterations, modifications as well as repairs to the EVG UVT may be carried out. Opening the device or breaking of the existing device inspection seals will void all warranty claims!

---

### 3 Transport, storage, delivery

The EVG UVT will be delivered in an appropriate packing.

Any damage detected must be documented at once and reported immediately to your specialist dealer or directly to UV-Technik international.

---

**NOTE!**

Packing material must be disposed of in an environment friendly way or re-used if possible. We would recommend that the packing material is kept to protect the equipment if it needs to be shipped onward or otherwise transported.

---

### 4 Order data for equipment

The equipment range can be found under item 6.

The sales department of UV-Technik international advice you regarding the correct equipment for the used lamp type and explains differences in detail.

### 5 Faults

#### Generaly

The following fault lists contain information on faults which may occur on the EVG UVT, possible causes and tips on how to remedy the fault.

If a fault occurs on your equipment and cannot be remedied by following these instructions, contact the customer service department of UV-Technik international.

In the event of a malfunction or in the event of a fault, the EVG UVT switches off the lamps. The detected fault status is indicated via the potential-free contact and, for some devices, a flashing code of the red LED. An error condition remains until the mains voltage is switched off. Once the cause of the fault has been rectified, the device can be put into operation again.



## Failure table

fault	fault description, possible cause	measures
ignition problem	lamp fault (e.g. leaky lamp) filaments of the lamps do not glow/preheat connection fault /loose connection ignition voltage drop above the cable too high lamp too cold	replace lamp wrong lamp, connect correct lamp check cabling, clamps shorten lamp cable, enlarge cross section observe lamp product information
breakdown	due to short circuit due to overheating due to wrong supply voltage due to malfunction	check cabling check cooling and $t_c$ -temperature check supply voltage check quality of mains supply
blinking of the power LED	meaning with the help of the description in the product information	eliminate fault resp. consultation with technical support
mechanical damage	transport damage improper handling	<b>instant</b> information to us replace ballast

## 6 Technical data

### General information

supply voltage	85...264 V AC 50/60 Hz	
power factor	> 0.95 (16W only 90%)	
efficiency	> 0.9	
operating frequency	approx. 28...70 kHz	
ignition	preheating approx. 3 s	
potential free contact (NOC) ohmic load for type, refer to next table equipment range	electromechanical relay: max. 5 A, 250 V AC max. 5 A, 24 V DC min. $\geq 5$ V DC / 100 mA	solid state relay: max. 230 V AC/DC max. 100 mA 35 Ohm internal resistance
standby current	approx. 2 W	
leakage current to PE	max. 2 mA (typical)	
weight	approx. 260 g	
allowed cable capacity	max. 200 nF (corresponds to approx. 1.5 m depending on cable capacity and installation)	
wire cross section	0.5 – 1.0 mm <sup>2</sup> , 20-17 AWG (stranded wire up to 0.75 mm <sup>2</sup> ) <b>Do not use crimping ferrules!</b>	
failure monitoring	lamp presence check before start (start prevention if no lamp is connected) lamp fault lamp at end of life time short circuit lamp wires	
status display	LED	
CE conformity	EN 61347-1, EN 61347-2-3, EN 55015, EN 61000-3-2, EN 61547	

### Equipment range

article number	type	$I_L$ [mA]	typical lamps	wiring type	relay
203 00500 0000	EVG UVT 40W **	425	UVN 40, TUV 36 T5, TUV 36W	3	solid state
203 00505 0000	EVG UVT 2x40W	425	UVN 40, TUV 36 T5, TUV 36W	4	solid state
203 00506 0000 *	EVG UVT 80WHO	800	UVN 80HO, TUV 36 T5 HO, TUV 75W HO	1	solid state
203 00508 0000	EVG UVT 75WHO **	800	UVN 80HO, TUV 36 T5 HO, TUV 75W HO	2	electromech.
203 00510 0000	EVG UVT 16-25W ***	400	UVN 16, TUV 16 / 20 / 25 T5	1	solid state
203 00511 0000	EVG UVT 40WHO	800	UVN 40HO	1	solid state
203 00512 0000	EVG UVT 30WHO	700	UVN/UVI 30HO	1	solid state
203 00514 0000	EVG UVT 55WHO	540	TUV PL 55W HO	1	solid state
203 00515 0000	EVG UVT 20WHO	670	UVN/UVI 20HO	1	solid state
203 00517 0000	EVG UVT 75W **	425	UVN80, TUV 64 T5	2	electromech.

\* expiring item

\*\* devices with 2 LEDs, fault indication via flashing code (see the following table LED display)

\*\*\* from  $\geq 20$ W only with 230V supply

## Installation instructions

designed for	installation in electrical cabinets
IP protection code	IP20
size of housing (L x B x H)	230 x 40 x 30 mm
mounting position	arbitrary
ambient temperature	ta = 0...50°C
relative humidity	max. 80% not condensing
temperature at tc - point	tc = 70°C max. at housing

## LED status indicator for types with blink code

ballast status	failure contact	LED red	LED green	description	possible causes
start / preheating	off	on	on	ballast in preheating	
normal operation	on	off	on	system lamp/ballast ok	relay switches after preheating/start
start condition not fulfilled	off	steady blink	steady blink	ballast is waiting for start	- no lamp - lamp plug disconnected or cable break - mains under- or overvoltage - start at overtemperature
temperature failure	off	blink 1x	off	cut off by persisting overtemperature, tc-temperature exceeded, too high ambient temp.	- insufficient heat dissipation - wrong installation position - housing / cabinet too small - cabinet fan (cooling) out of order
supply voltage incorrect (during start)	off	blink 2x	off	supply voltage incorrect at start	- mains voltage out of the allowed range
Intermediate circuit voltage incorrect (at start)	off	blink 3x	off	cut off at start due to incorrect intermediate circuit voltage	- internal failure
reserved	off	blink 4x	off	not used	
preheating current too low	off	blink 5x	off	cut off due to insufficient current during preheating	- filament resistance too high - cable too long /too thin
supply voltage incorrect (during operation)	off	blink 6x	off	supply voltage incorrect during operation	- mains voltage out of the allowed range
Intermediate circuit voltage incorrect (in operation)	off	blink 7x	off	cut off during operation due to incorrect intermediate circuit voltage	- internal failure
lamp voltage incorrect	off	blink 8x	off	cut off by monitoring of abnormal lamp voltage (too high or too low)	- wrong lamp type connected - lamp at end of life time (rectifier effect) - deactivated lamp during operation - incorrect operation conditions of the lamp (too cold / too warm)
overcurrent at half bridge	off	blink 9x	off	cut off by overcurrent at the half bridge (abnormal operation)	- lamp cabling failure - short circuit in the lamp cabling - ignition not possible/successful - lamp failure

when blinking, please count the light phases, e.g.:

**Dimensional drawings**

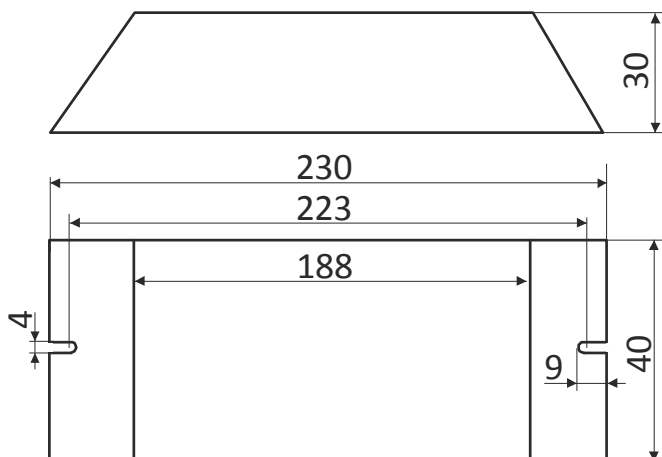

**Connection plan**

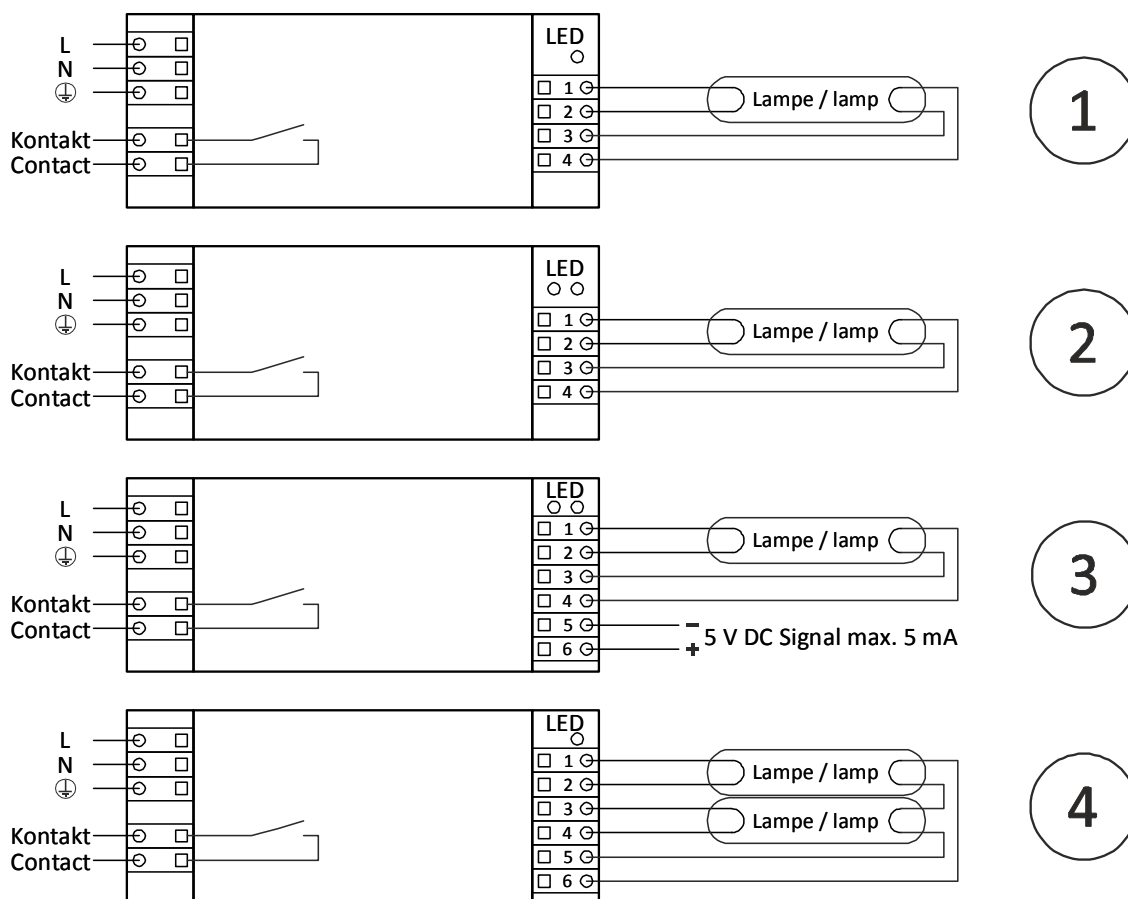

## 7 Hints for installation

### Point of installation

The EVG UVT may only be installed and operated in a dry, chemically and biologically inactive environment. The assembly must not be carried out in vibrating parts. Information on IP protection must be observed. The EVG UVT must be properly grounded. It is usually installed on a grounded base plate, which in the ideal case also takes up some of the waste heat from the equipment and transports it away. Suitable screws with high screw heads must be selected for fastening and the distance between the mounting holes must be observed. When screwing on, ensure that the screw heads do not protrude under the circuit board (danger of short circuit!).

The EVG UVT and its cabling should be installed separately from other system components and their cabling. This applies in particular to control, signal or sensor lines, which usually only have small voltages or currents.

### Connection / cabling

The EVG UVT must be connected according to the wiring diagram and the sticker on the device. The device is equipped with spring-loaded terminals which are designed for use with rigid or flexible cables. Wire end ferrules are not recommended and can damage the terminals when loosening the connection. The possible cable cross sections are given in the product information. The length of the stripping of the cores must be adapted to the insertion depth of the terminals and is indicated on the label. Check the tightness of the cables. Short circuits, incorrect connections and wobble contacts can lead to malfunctions and damage.

### Cabling of lamps

The cabling of the lamps has to be carried out individually. It is not permitted to route several lamp leads in a multi-core cable. Cable connections to the lamp must not be disconnected during operation. By no means install additional components in the lamp supply cable, such as relays, switches, ignitors or capacitors. The number of the clamping points in the lamp cable should be reduced to a minimum, if possible any additional clamping should be avoided. Designated clamps and connectors must be checked carefully, not only regarding electrical data but necessarily also relating to temperature and environmental conditions. Clamp contacts must be protected against corrosion. Sparks at corroded clamps could cause disfunctions or breakdown of the EVG UVT and imply fire hazard.

Since the lamps are operated at high frequency, the connection cables emit disturbances. Therefore they must never be laid parallel to mains or control cables. In order to avoid EMC problems, they must also be kept as short as possible. The maximum length or the maximum cable capacity, as specified in the product information, must not be exceeded. Shielded cables are allowed to reduce the interference radiation. However, it should be noted that the cable capacity is thereby increased. Also due to the parallel installation of the lamp cables, as well as by metal mounting surfaces or cable ducts, a higher capacity results. The sum of these parasitic capacity detunes the oscillator circuit in the EVG UVT. This can lead to ignition problems and a deviant lamp current.

### Mains supply cabling

The mains cabling must have a low impedance and the mains cable must be laid so as to minimize interference caused by emissions from the lamp cables. For this reason, the mains cables must be kept short and must not be laid parallel to lamp cables or tightly along the housing of the EVG UVT. Crossings with lamp leads should be avoided if possible. If necessary, such intersections must be at right angles and at a certain distance. Unavoidable noise interferences must be filtered with appropriate interference suppression measures. For complex installations, network filters must be provided if necessary. In principle, the prevention of faults is preferable to the fault elimination.

## Grounding

A clean earth potential and a proper grounding with an adequate cable cross section are the preconditions for compliance with the EMC standards. Only if this is guaranteed, high frequency disturbances can be derived and thus prevented. Therefore, always connect all grounding terminals. Ground the mounting base plate. Do not forget to ground the cabinet door. Use toothed washers for a reliable contacting of painted surfaces/housings. Avoid ground loops.

## Additional notes for cabling

Any damage to the cables must be avoided. Cable routing through housings shall have no burrs and must be adequately insulated. The same applies to edges touched by the cable. Use cable glands and bent protections and consider the allowed bending radiuses. The cable specification must comply with the environmental conditions on site. If necessary, special cables need to be used (e.g. waterproof, oil- or flame-resistant, etc.). Should cables be exposed to UV radiation or to ozone, generated by UV lamps, they must be insulated with Teflon (PTFE) or fibre glass. All other materials are not sufficiently UV-stable and need therefore to be protected in an appropriate manner.

## Temperature behaviour

The lifetime of an electronic device is determined by the error rate of the electronic components of which it consists. Generally spoken, the higher the temperature, the higher the error rate, the shorter the lifespan. In the EVG UVT, the electrolytic capacitor is the lifespan-determining component (see chart). We use only premium-quality capacitors of the highest temperature stability. In compliance with the installation instructions as well as the maximum housing temperature, a lifetime of at least 50,000 hours is expected. That a temperature change of 10K doubles or halves the life of the capacitor can be seen as rough calculation. Please make sure that the specified maximum case temperature is not exceeded even in extreme operation (worst case). If you measure the temperature contact-free, please make sure that the correction factor for the measured surface is adjusted correctly. Otherwise, significant measurement errors may occur.

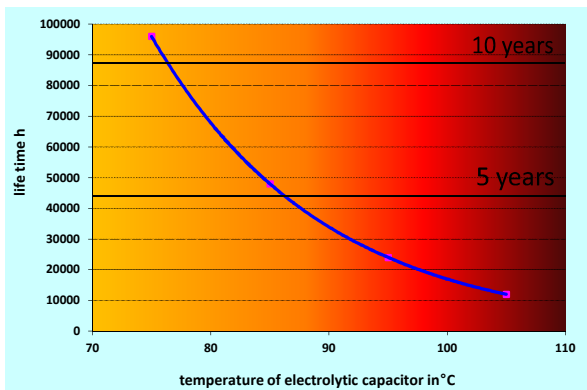

premium-quality capacitors of the highest temperature stability. In compliance with the installation instructions as well as the maximum housing temperature, a lifetime of at least 50,000 hours is expected. That a temperature change of 10K doubles or halves the life of the capacitor can be seen as rough calculation. Please make sure that the specified maximum case temperature is not exceeded even in extreme operation (worst case). If you measure the temperature contact-free, please make sure that the correction factor for the measured surface is adjusted correctly. Otherwise, significant measurement errors may occur.

A sufficiently large cabinet should be chosen. The contained air must be able to circulate. If possible, use sheet metal housings. In comparison, plastic and stainless steel are the worse heat conductors. Also with regards to the shielding of electromagnetic radiation caused by the ballasts, the sheet metal is the best choice. When calculating the size of the cabinet according to the specified loss, do not forget to add the loss of other build in components. Assemble the ballasts if possible in the lower part of the cabinet, as it is cooler. The distance between the EVG UVT must be at least 1 cm. Do not restrict the air convection with other fixtures or installation channels. If you need to assemble the devices above each other, please note that their operation is influenced by heat generation. The maximum case temperature must not be exceeded even for the upper unit. Avoid the input of heat from the outside. Assemble a roof for shading the control box for example. Decouple warm lamp housings from the ballast housings. Otherwise, it is of course beneficial to couple thermally cold equipment (e.g. reactor with cold water) to the cabinet of the EVG UVT. Turn on active cooling when overheating threatens. Wait long enough while doing temperature tests to reach the thermal balance of the ballasts. This can take up to several hours. Try to keep the case temperature of ballasts for most of the time below the maximum allowable temperature (approx. 10K less). Hence, you will achieve a longer lifetime and better operating safety.

## Switching

When switching the EVG UVT on an inrush current pulse of very short duration arises by the up-charge of the integral storage capacitor for the internal power supply. So choose the fuses not only by the indicated

operating currents, but also by the impact load. If possible, use slow-blow fuses. The same applies to the ground fault circuit interrupter (GFCI), which is triggered either by the high temporary inrush current or a low continuous current. Here, the leakage currents arise on the interference suppression capacitors of the EVG UVT. If allowed, please install a surge resistant, short-delayed GFCI protection switch with 30 mA. Should the maximum possible number of EPS be exceeded for fuse or GFCI, they must be grouped appropriately. In doing so, care must be taken to ensure the uniform load on the phases.

Please avoid repeated switch-off and on cycles of electronic ballasts. Wait at least 10 seconds after shut down before the next switching. In extreme switching loads you should check with the service of UV-Technik international first, if the selected device is suitable for your application.

If a failure is indicated, the EVG UVT needs to cutoff from the mains voltage. This will reset the failure status and internal counters. After having eliminated the failure cause, you can start the EVG UVT again. The restart after a power failure will be carried out automatically.

## Monitoring

In addition to the usual operating LEDs, the EVG UVT has a potential-free output, which signals the proper function. It switches on as soon as the lamp is in operation and can be used for display/signaling or for switching functions. The output is either an electromechanical relay or a solid state relay with opto-coupler. Observe the values given in the technical data. Depending on the type, the permissible minimum and maximum load as well as the internal resistance must be observed. Avoid inductive or capacitive loads. In addition to the permissible maximum load, the minimum load must also be considered, in particular for relays. Since relay contacts are burned free/cleaned by the sparks generated during switching, the continuous operation with too low current or too low voltage can lead to contact problems. This is particularly important if the signaling contacts are to be connected directly to a PLC where normally only 5 V and a few mA flow in the signal circuit. A series connection of signaling contacts should be avoided. If this is unavoidable, detector rings must be formed with as few devices as possible. Voltages/currents in the signaling circuit should then be clearly above the permitted minimum values.

In addition to the relay signal output, individual EVG UVT have a 5 V output. This can be connected directly to an input of a PLC or to the connection of an external operating LED. This function is helpful if the operating state must be displayed on the front of the switchbox. The information in the product information regarding the permissible load must be observed.

## Dimming

The EVG UVT have by default no dimming function. Please never try to dim the EVG UVT by changing the mains supply voltage. The integral PFC regulates fluctuations in the supply voltage, so that there is no influence on the output power. Mains voltages out of specification cutoff the ballast and may cause damages.

## Electromagnetic compatibility

The EVG UVT comply with the standards mentioned in the technical data and the CE declaration. As a part of a system, other/further rules may be valid. It is the responsibility of the manufacturer/installer or generally the operator to check the complete system according to the relevant rules. If several ballasts are build in a system, in generally additional measures can be necessary to eliminate interferences.

Beside the observance of the thresholds of the supply voltage, the mains supply may not be loaded with distortions, burst and surge disturbances. If the mains quality is unknown, the installation of filters and overvoltage/lightning protectors is recommended. An undisturbed mains supply is the precondition for a failure-free operation.

In addition to the known technical contexts, all given instructions of this document are based on our experiences. We take no guarantee of completeness and correctness.